

# NYX

## FOCUSED ON VISION



## AUTOFOCUS

The NYX HD-SDI camera incorporates the latest autofocus lens technology ensuring the sharpest high definition image at all times, day and night.



## POWER ZOOM

2.8-12mm push button motorized zoom function makes installing the NYX faster and easier.

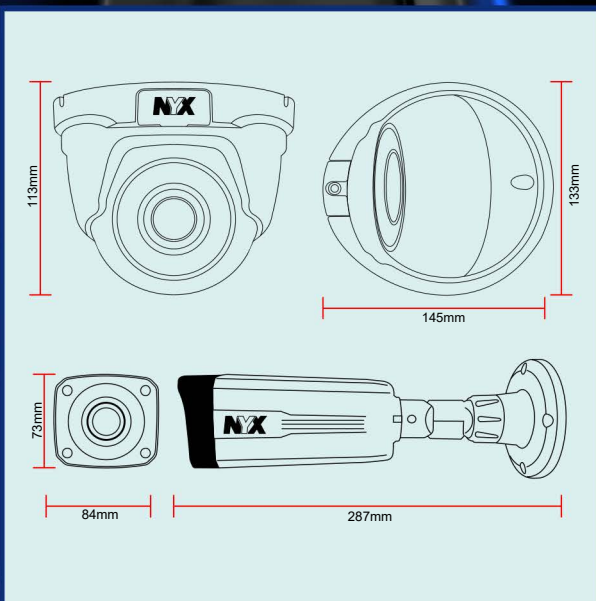

Image Sensor	2.1 Mega Pixel 1/3" Panasonic CMOS Sensor
Effective Pixels	1944(H) x 1092(V)
Lens	3MP 2.8-12mm Motorized Zoom Lens
Min Illumination	0 Lux (IR LED ON)
IR View Distance	35M
OSD	Built-in
WDR	OFF/ON (Level Adjustable)
3D DNR	OFF/ON (LOW/MIDDLE/HIGH)
Sens-up	OFF/ON
Motion Detection	OFF/ON
Privacy Zone	OFF/ON
HLC	OFF/ON
BLC Control	OFF/ON
Defog	OFF/ON
White Balance	AWB/ATW/PUSH/MANUAL
AGC	HIGH/LOW
Electronic Shutter Speed	AUTO/MANUAL/FLK
Video Output	HD-SDI / CVBS
Operation Temperature	-10°C to +50°C
Operation Humidity	Within 95% RH
Power Supply	DC12V (+/-15%)
Power Consumption	120mA / IR LED ON:400mA Max